

BS5153 CAST IRON SWING CHECK VALVE



*Valve complete with compatible flanged Bauer couplings, gaskets, nuts, bolts and washers.

Size	Weight Kg
2"	12
3"	22
4"	37
5"	56
6"	73
8"	122
10"	201
12"	291

FEATURES:

Flanged and drilled to BS4504 PN16.
 Metal to metal seat and disk.
 Face to face dimensions.
 To BS4504 Series.
 Shell : 24 bar.
 Pressure/temperature rating.
 Manufactured in accordance with BS5153.
 Maximum temperature 120°C @ 16 bar.
 Test pressures (Hydraulic)
 Seat : 17.6 bar.

BS 5150 CAST IRON GATE VALVE



*Valve complete with compatible flanged Bauer couplings, gaskets, nuts, bolts and washers.

Size	Weight Kg
2"	17
2.5"	22
3"	27
4"	48
5"	68
6"	87
8"	118
10"	197
12"	275

FEATURES :

Hand wheel operated.
 Non-rising stem.
 Bolted bonnet.
 Flanged and drilled BS4504 PN16
 Face to face dimensions comply
 with BS 5150 PN16.
 Maximum pressure 16 bar @ 10°C to 120°C.
 Test pressures (Hydraulic)
 Shell : 24 bar.
 Seat : 16 bar.

RESILIENT SEATED SWING CHECK VALVE

CARRIAGE PAID



- ✓ Flanged and drilled to BS 4504 PN16.
- ✓ Resilient seated disk.
- ✓ Epoxy coated ductile iron body.
- ✓ Face to face dimensions to BS5153 : 1974 (1991) short.

Pressure / Temperature rating

Manufactured in accordance with BS 5153

Maximum temperature 70°C @ 16 bar

Test Pressures (Hydraulic

Shell : 24 bar

Seat : 17.6 bar

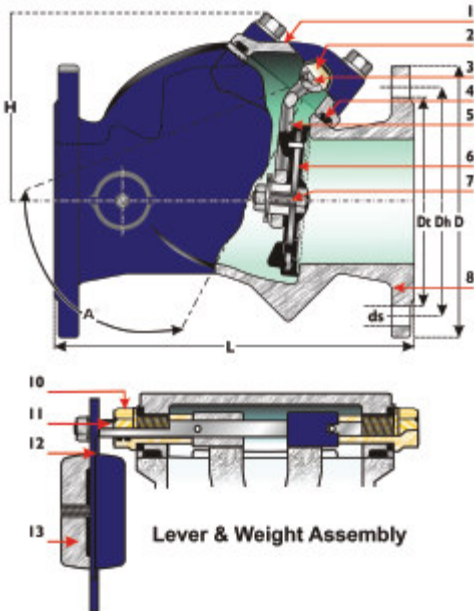

Outside lever and weight available as an optional extra. (as illustrated)

Dimensions (mm)

DN	80	100	150	200
L	241	292	356	495
H	140	150	195	230
D	200	220	285	340
D1	138	158	212	268

PART	MATERIALS
Body	Ductile iron to BS EN 1564 GGG-50
Bonnet	Ductile iron to BS EN 1564 GGG-50
Body/Bonnet seat	EPDM
Bushing	DZR Brass to BS2874 CZ 132
Disk Assembly	Steel to BS4360 1979 43B fully encapsulated in EPDM
Hinge	Ductile iron to BS EN 1564 GGG-50
Hinge Pin	S/Steel to BS970 Gr 431 S29
Nuts & Bolts	S/Steel to BS2874 CZ114
Seat	Integral with the body

WAFER CHECK VALVE

*Valve complete with compatible flanged Bauer couplings, gaskets, nuts, bolts and washers.

Size	Weight Kg
2"	1
2.5"	1.2
3"	1.5
4"	2.4
5"	3.4
6"	4.6
8"	7.5
10"	13.1
12"	20.4

Single Plate. Zinc plated steel. Over Ø 200mm.
Centering PN10. NBR (Nitrile). Seal on the seat.
For water, HEVAC, industrial general applications.

BUTTERFLY VALVE

*Valve complete with compatible flanged Bauer couplings, gaskets, nuts, bolts and washers.

Size	Weight Kg
2"	2.5
2.5"	3.2
3"	3.6
4"	4.9
5"	7
6"	7.8
8"	13.2
10"	19
12"	32.5

Cast Iron PN16 Butterfly Valves.
DN50 to 350mm, EPDM Seals and ductile iron discs.
Suitable for water and air installations.